



# Drain Master Electric Gate Valve



## Product Data

**Drain Master is an electrically operated, one touch gate valve designed to replace standard 3" gate valves on both motorized and towable recreational vehicle applications.**

- Made of durable, injection molded ABS plastic.
- Ideal for black and gray water tank installations.
- Very fast gate opens or closes in less than one second, initiated by a switch located virtually anywhere on the vehicle. Two switch remote location optional.
- Weighs less than two pounds, with ultra sleek profile.
- Features 303 Stainless Steel, double sided manual override and gearing made in Switzerland
- Operates on standard 12 volt RV systems, and draws less than 5 amps during operation.
- Standard 3 inch pipe fittings and remote switching features provide maximum design placement flexibility.
- Reducer kit available for smaller piping



**Drain Master**  
**The Perfect Solution**

[www.drainmaster.com](http://www.drainmaster.com)

877-787-8833



### Technical Specifications

- Width 6"
- Height 10"
- Depth 1 3/4" - 3/4"
- Valve Size 3"
- Weight 1 lb 14 oz
- Voltage 12 Volts DC
- Consume 2.5 amps per cycle
- Wire 20 AWG

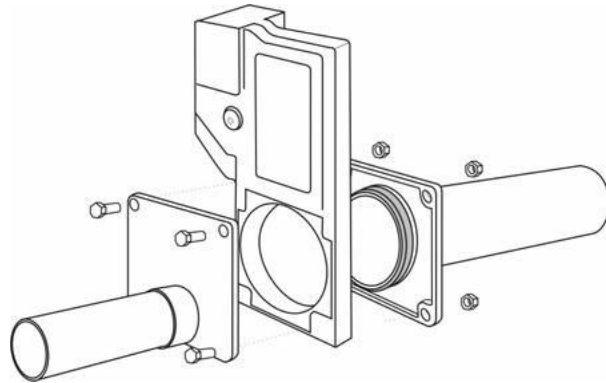

Torque Spec for Flange Bolts: 10 Inch – pounds  
(Do not exceed 15 Inch – pounds)

### Testing Data

Continuous Cycle Test	Cycle Weeks	=	Per Year	÷	Cycles	=	Years
	3 x 52		156		6000		38.46



[www.drainmaster.com](http://www.drainmaster.com) 877-787-8833

# Valve Orientation

