

# S3VT Operating Switch and Cable Installation

Essential items that work together to operate S3VT valves

## Doc DM102

### Contents

- DM PN 5787- DM30 - SVT Single switch install – Pages 2-5
- DM PN 5847- RV Dbl SW PNL Double switch panel install – Pages 6-7
- DM PN 5955-IP66-2 20' Rnd. Interface Cable Ass. install – Pages 8-12
- Single switch insertion method – Pages 13-15
- S3VT Companion Document information – Page 16



Questions?  
Call 1 877 787 8833

# S3VT Operating Switch and Cable Installation

## 1. Direct Panel Mounting - Single Switch, DM PN 5787- DM30 - SVT

### 1.1 Fig. 1 – Panel Cutout

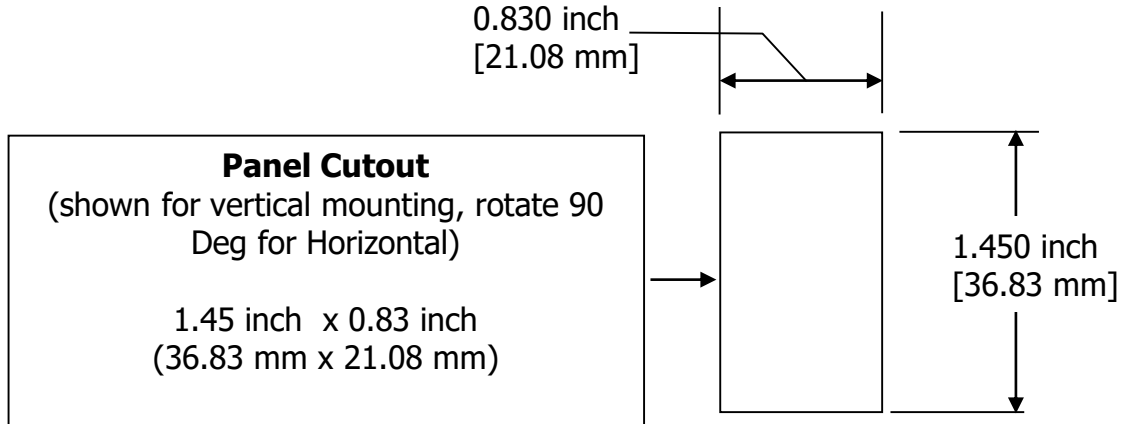

**Fig 1.**

### 1.2 Fig. 2 – Mounting panel thickness and rear clearance

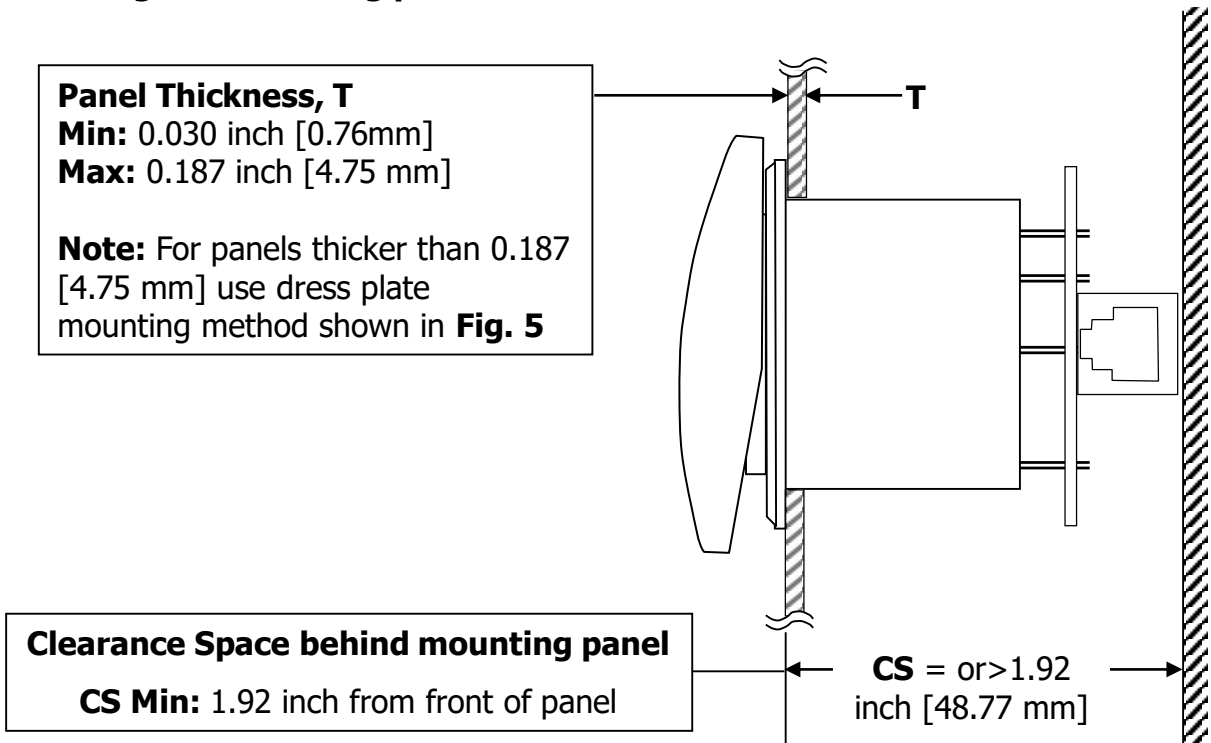

**Fig 2.**



Questions?  
Call 1 877 787 8833

# S3VT Operating Switch and Cable Installation

## 1.2 Multi Switch interspacing using direct panel mounting:

**Fig. 3 and 4** show minimum centre to centre requirements for 2 orientations: Vertical Layout (**Fig. 3**) is the prevalent industry practice.

Horizontal Orientation (**Fig. 4**) (use if space limitations restrict vertical mounting)

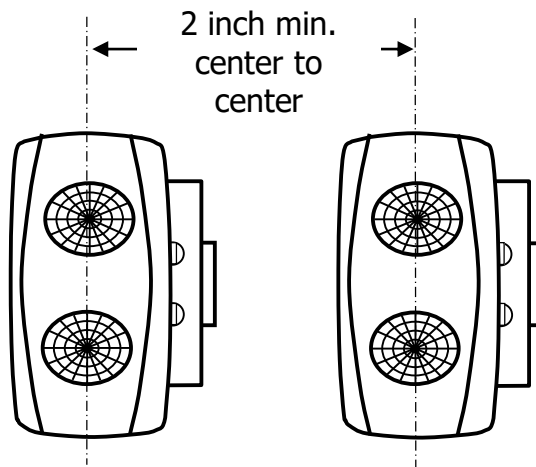

**Fig. 3 VERTICAL**

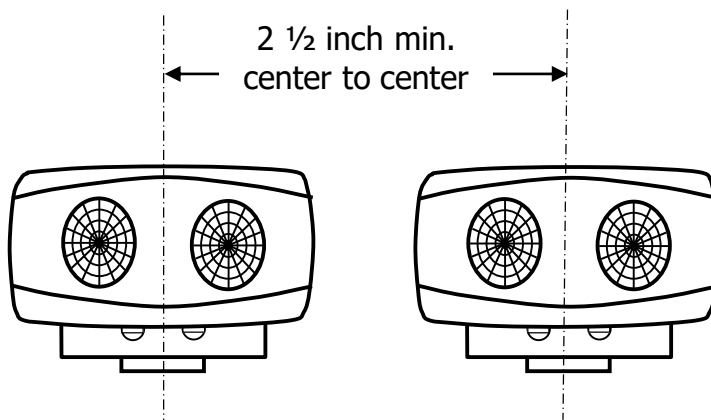

**Fig. 4 HORIZONTAL**



Questions?  
Call 1 877 787 8833

# S3VT Operating Switch and Cable Installation

## 2. Single Switch PN 5787 - DM30 - SVT Mounting using Dress Plate

### 2.1 Fig. 5 – Panel cutout and dress plate dimensions:

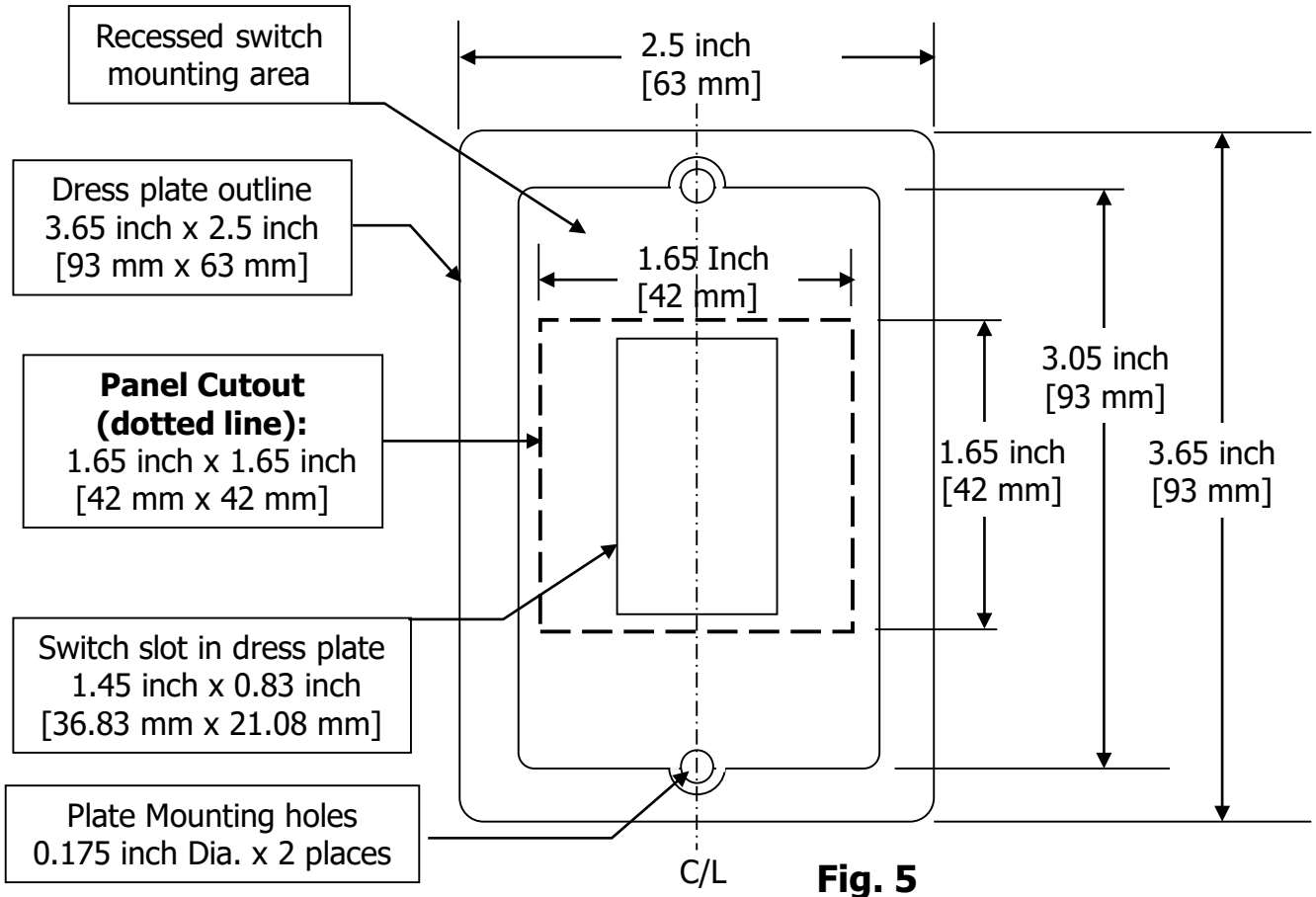

#### **Panel Thickness:**

Min: Not specified – Panel thickness must adequately support dress plate  
Max: 1 inch [25 mm]

### 2.2 Multi switch interspacing using dress plate:

**Vertical mounting** is prevalent industry practice - requires center to center > **2.5 inch**  
**Horizontal Mounting** (use if space limitations restrict vertical mounting) requires center to center > **3.65 inch**



Questions?  
Call 1 877 787 8833

# S3VT Operating Switch and Cable Installation

## **3. Switch Operating Orientation: Fig 6 A, B and 7 A, B (applies to both direct panel mounting or using dress plate)**

The RED LED ('Valve Open') indicator is on the 'Press to Operate' side.  
Vertical mounting with **bottom press** RED LED down as in **Fig 6 B** is the industry accepted practice and recommended.

**R-Red LED G-Green LED**

### **VERTICAL**

Top Press Operation

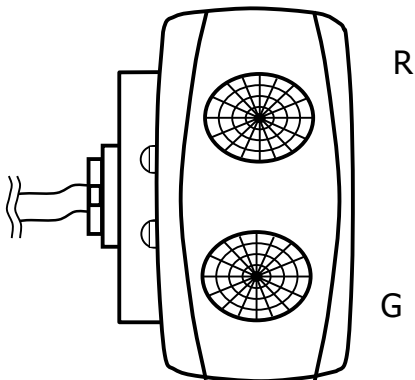

**Fig. 6 A**

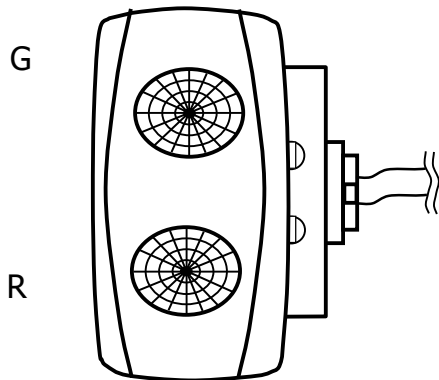

Bottom Press Operation

**Fig. 6 B**

### **HORIZONTAL**

Left Press Operation

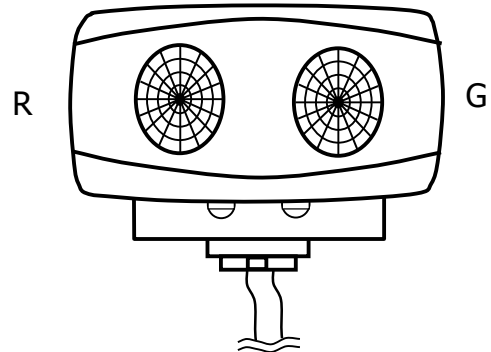

**Fig. 7 A**

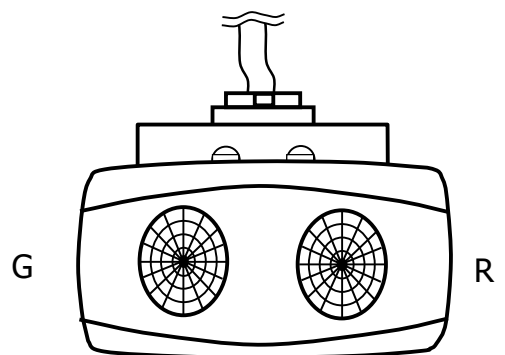

Right Press Operation

**Fig. 7 B**



Questions?  
Call 1 877 787 8833

# S3VT Operating Switch and Cable Installation

## 4. Double Switch Panel Mounting DM PN 5847- RV Dbl SW PNL

**4.1 Important:** Double switch panel is ideal for 2 valves operated from inside the RV. It is also great on outside RV panels or compartments protected from direct water exposure. Modest water contact, such as droplets, condensation or operating the switches with wet fingers is OK. The graphics are water, UV and wear resistant.

*Use DM PN 5787- DM30 - SVT (IP66 compliant Switch) where water exposure is expected and unavoidable.*

**4.2 Fig. 8 -** Cutout provides ¼" relief all around the circuit board behind the panel.

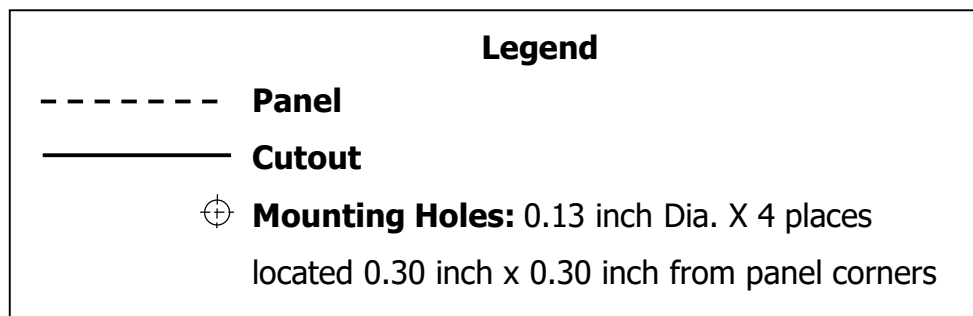
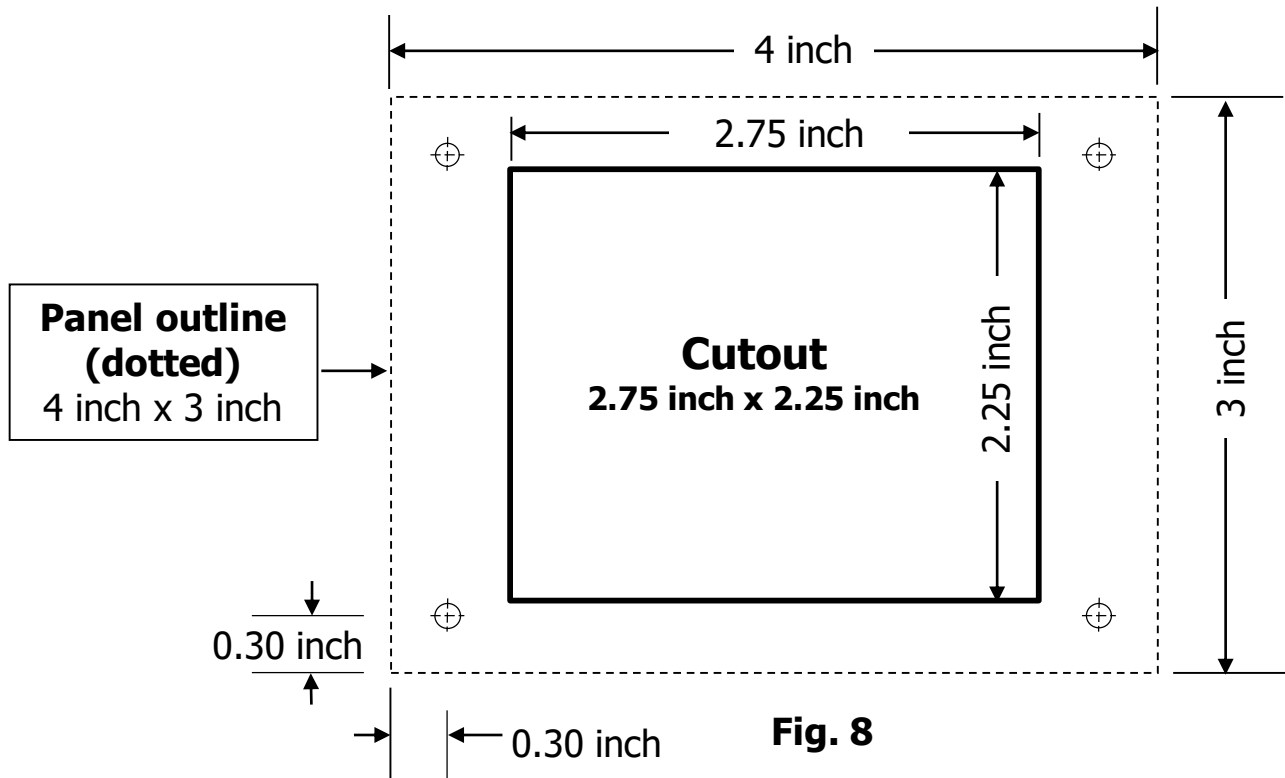

Questions?  
Call 1 877 787 8833

# S3VT Operating Switch and Cable Installation

## 4.3 Fig. 9 – Double Switch Panel DM PN 5847- RV Dbl SW PNL- Mounting panel thickness and rear clearance

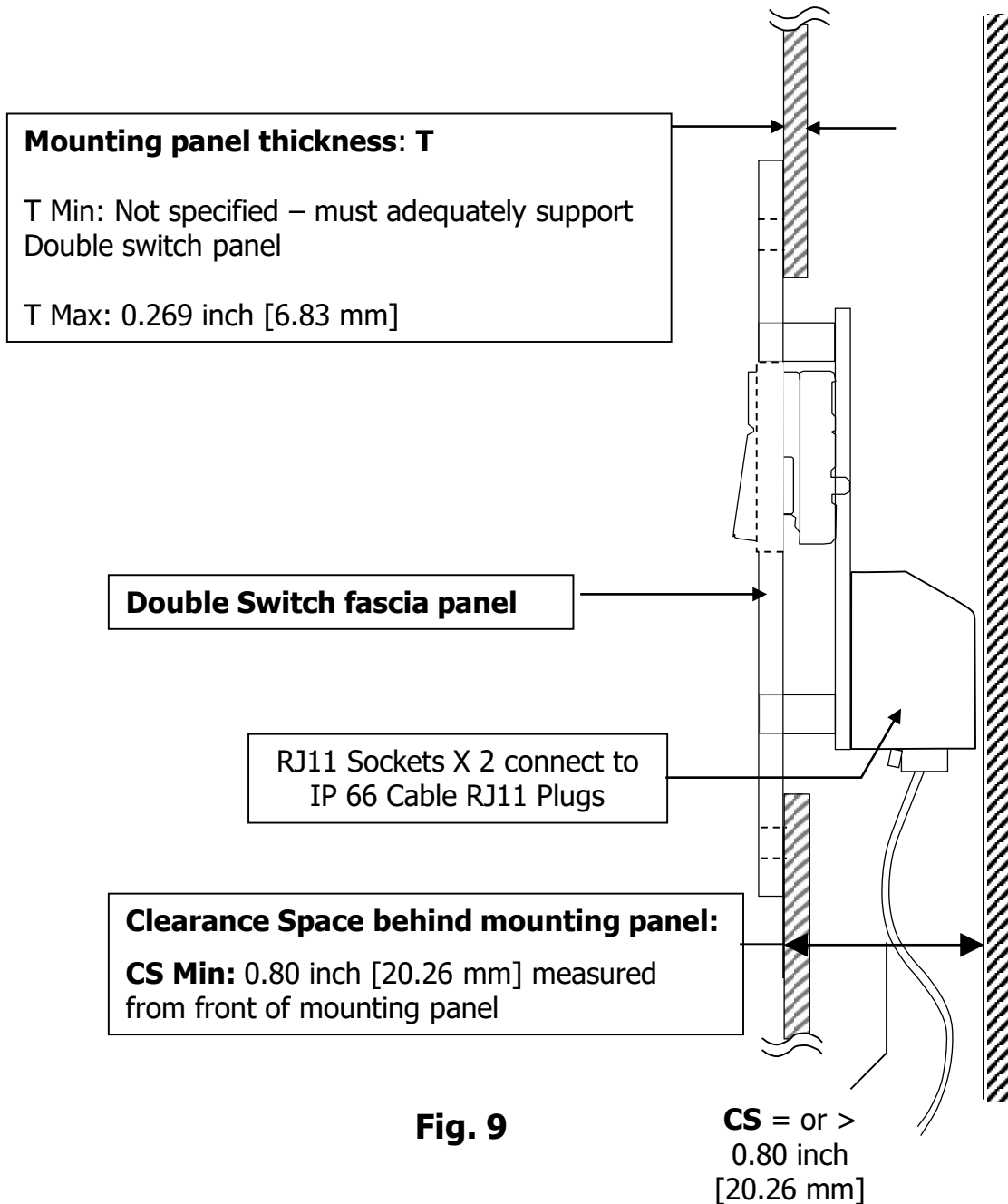

**Fig. 9**



Questions?  
Call 1 877 787 8833

# S3VT Operating Switch and Cable Installation

## 6. IP66-2 Interconnect (Male) Cable and Controller Port (Female) Cables

**6.1 IP66-2 Cable Connectors – Fig. 10:** IP 66 interconnect cable DM PN 6000-IP66-20' Rnd. Cable Ass. comes with a molded waterproof (IP 66 rated) 4 pin **Male** connector at one end an RJ11 plug on the other. RJ 11 plugs into the operator switch socket.

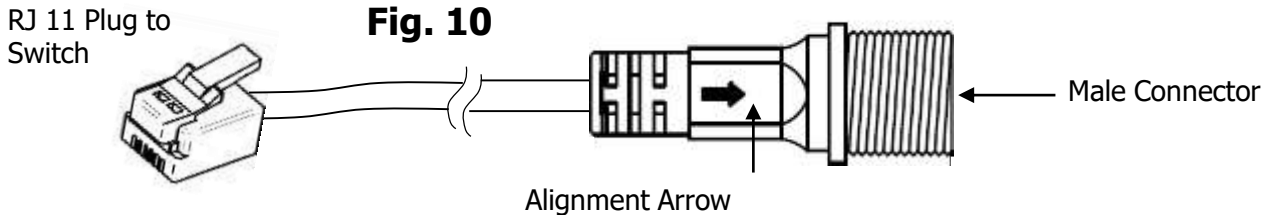

**6.2 Valve Controller 2 port cable connectors – Fig 11 A, B:** Each Port comes with Molded 4 pin **Female** waterproof connector that connects to an IP66-2 cable Male (Fig. 10) or is capped if unused (Fig.13)

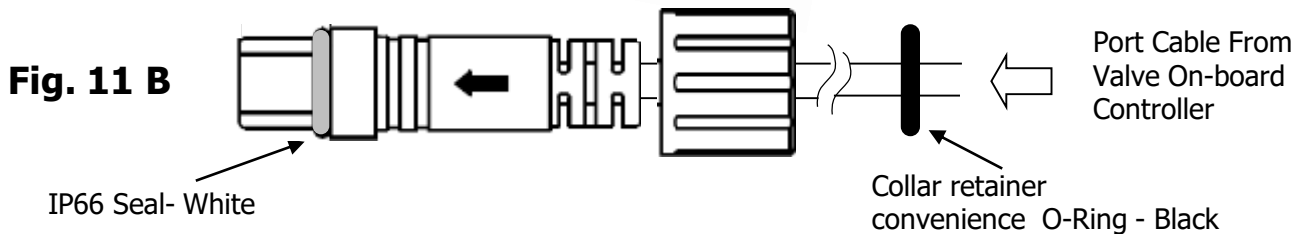

**6.3 IMPORTANT:** Waterproof (IP66) compliance is achieved when Male and Female connectors are securely mated and collar is tightened thereby compressing the IP66 Seal (white O-ring) located on the female barrel as shown in Fig 11 B. It normally resides under the collar and must always be in place - do not dislocate from connector.

**Do not expose to water unless M- F connectors are securely mated. Doing so may cause erratic operation, damage or corrosion and violate warranty.**

[Note: The black O-Ring shown is simply a convenience retainer for the collar, not a seal. It's location is not important and it is normally slid over the connector barrel behind the collar. Position it to allow the collar to open fully but prevent it from sliding too far back on to the wire]



Questions?  
Call 1 877 787 8833



# S3VT Operating Switch and Cable Installation

## 6.5 Dual port (2 Switch configuration)

To operate the valve a switch must be connected to a port via the IP 66-2 cable. All valves are capable of 1 or 2 switch operation. Depending on your kit or configuration, One or more switches or Double Switch Panel/s would be included or can be easily added later. Switch operation and LED indications work identically from each switch; switches and cables are functionally interchangeable making servicing very convenient.



**6.4 Single Switch Operation and Port Cover:** A valve configured for single switch operation **MUST** have the unused port capped with protective cover to meet IP66 (waterproof) compliance (Fig 13). Upon receiving, check the cover is securely installed. It should only be removed if and when a 2<sup>nd</sup> switch is installed; keep safely for future use. Do not operate without the cover. (Fig 14)



Questions?  
Call 1 877 787 8833

# S3VT Operating Switch and Cable Installation

## 7. Mating IP66-2 Connectors

### 7.1 Coupling – Fig. 15 A

**Important: Complete IP66-2 cables routing and securing before final mating.**

- Connector are keyed and will engage only in the correct orientation.
- For user convenience white alignment arrows are marked on male and female.
- Rotate connectors till the arrows line up and engage them firmly till fully seated
- Grasp the Male barrel and screw the collar clockwise as shown
- Rotate collar till finger tight. To ensure waterproof sealing be sure its fully secure.

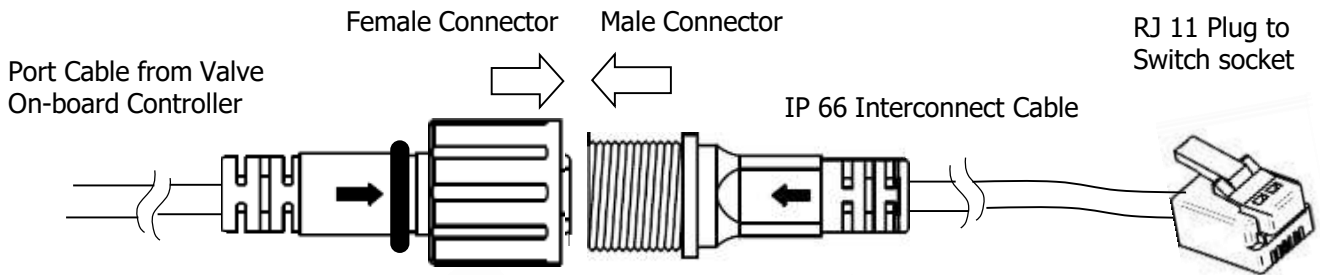

**Fig. 15 A**

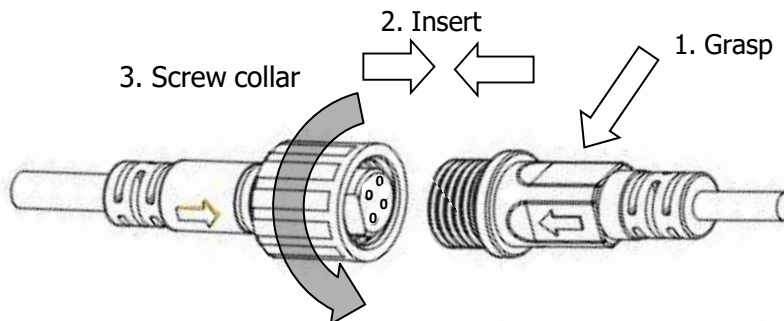

**7.2 Decoupling – Fig. 15 B:** As before, grasp the male barrel, unscrew the collar anticlockwise then separate connectors by firmly pulling straight out.

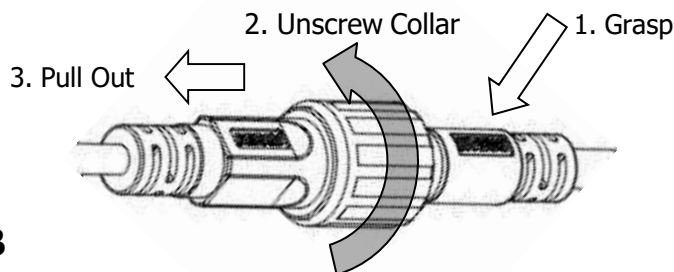

**Fig. 15 B**



Questions?  
Call 1 877 787 8833

# S3VT Operating Switch and Cable Installation

## 8. WIRE ROUTING:

**8.1 Option 1– Routing from Valve towards the switch:** This approach works favorably for switches or double switch panel installed on the outside of the RV where rear is accessible after install

- Start from valve, route IP 66 cable out through to behind the cutout.
- Install switch or switch panel; plug the RJ 11 into the switch socket (rear access required)
- Mate the Waterproof connectors on the valve side.

## 8.2 Option 2 – Routing from Switch towards valve:

Approach works favorably for switches or double switch panel on inside RV wall panel, for example, or where switch rear access in most cases is only possible before switch install

- Route IP 66 cable through the switch cutout and out to the valve.
- Plug the RJ 11 into the switch socket; then install the switch or double switch panel  
*[If the rear however is accessible, the RJ 11 plug may optionally be plugged into the switch socket after switch install]*
- Mate the waterproof connectors on the valve side.

## 8.3 Routing DONT's

- Don't yank or pull wire from the RJ 11 or 4 Pin Connector
- Don't damage the RJ 11 or 4 Pin Connector during layout
- Don't let excess wire weigh down on the RJ 11 socket or connectors
- Don't put sharp bends or kinks in the wire as shown in **Fig. 16** and **Fig. 17**

**Fig. 16:** Sharp bend



**Fig. 17:** Kink



## 8.4 Routing DO's (Sec 9. Pg 12 Examples: Fig.18 A – C and Fig. 19 A – C)

- Mark 'B' and 'G' on wire ends to eliminate guess work during insertion into switch!
- Pre-plan the routing path - IP66-2 wire is easy to layout & very flexible
- Protect wires over by automotive split sheathing
- Harness +12 V Power and IP 66 sheaths along the routing, closer to the valve, for ease
- Stress relieve using clamps & tie wraps; secure excess wire



Questions?  
Call 1 877 787 8833

# S3VT Operating Switch and Cable Installation

## 9. Routing DO's Examples: Figs. 18 A, B, C and Figs. 19 A, B, C

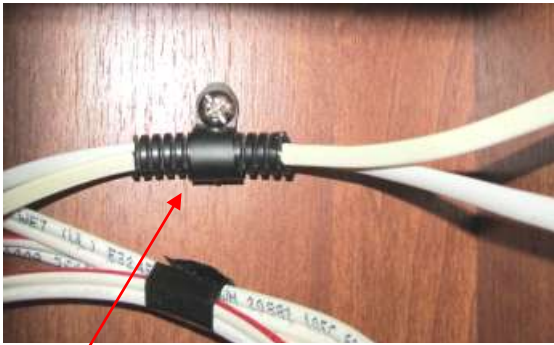

**Fig. 18 A** Outgoing wires to switches secured behind cutout with P-clamp

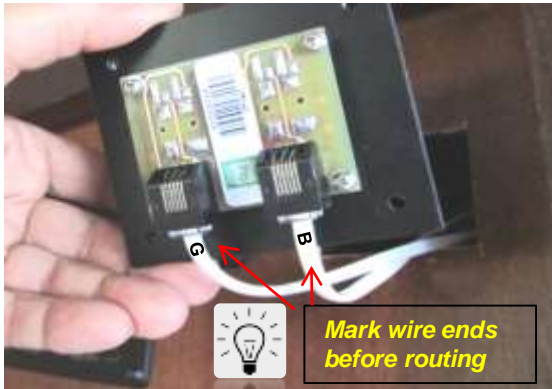

**Mark wire ends before routing**

**Fig. 18 B** RJ 11 ends exit from cutout and plugged into switch panel



**Fig. 18 C** Double switch panel mounted (Note: no rear access after panel mounting)



**Fig. 19 A** IP 66 wire pairs and 12V supply wires sheathed over and tie wrapped



**Fig. 19 B** P-Clamped for stress relief



**Fig. 19 C** Tie wrapped, labeled and excess wire secured adjacent to valve



Questions?  
Call 1 877 787 8833

# S3VT Operating Switch and Cable Installation

## 10. Single Switch Insertion:

**10.1 IMPORTANT:** Before proceeding determine if the RJ11 plug is to be plugged into the switch socket before or after switch installed. If rear access to the switch is not available plug in RJ11 first.

### 10.2 Step 1

- Angle switch as shown in **Fig. 20** to begin entry to the panel.

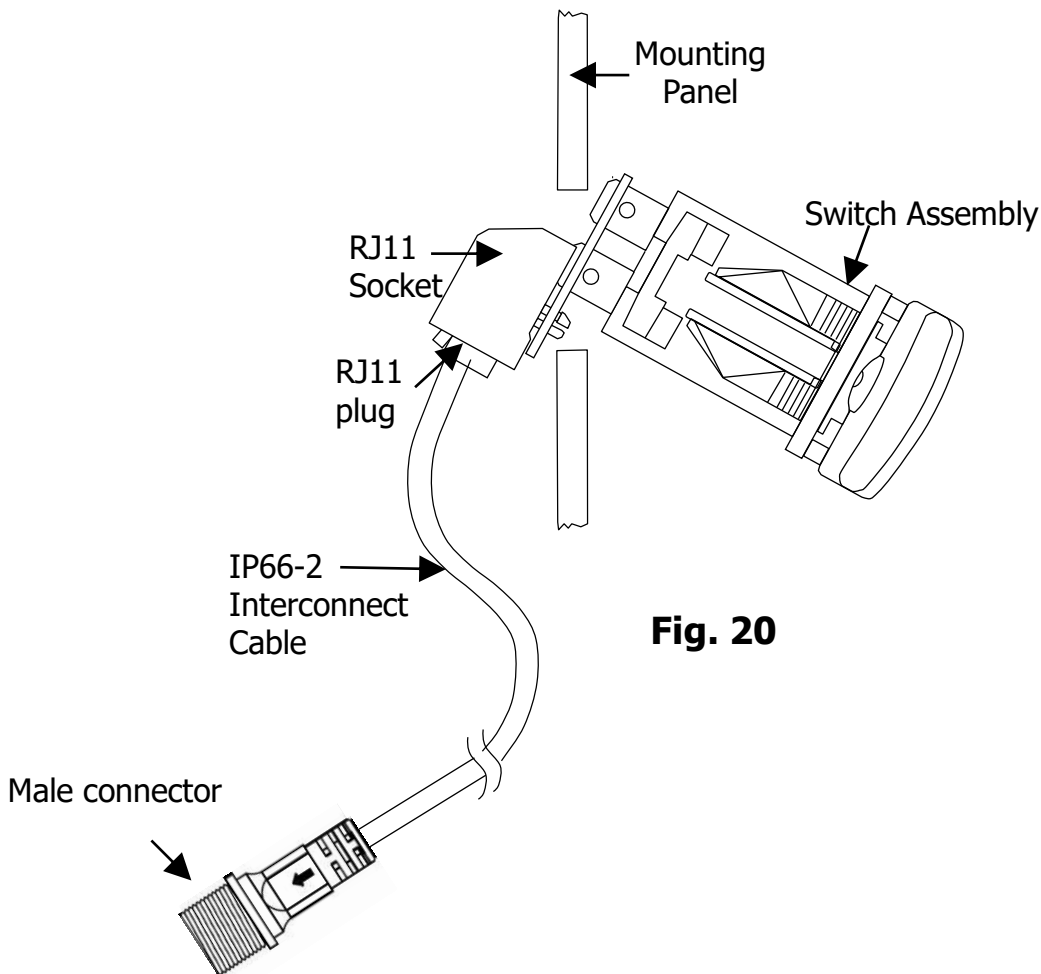

**Fig. 20**



Questions?  
Call 1 877 787 8833



# S3VT Operating Switch and Cable Installation

## 10.3 Step 2

- Rotate switch assembly into the slot as shown by the arrow in **Fig. 21**
- Lower switch assembly in so mounting panel edge resides in the tab space **TS**
- From this position ease switch assembly into the slot - it will slide in\*  
(\* For maximum allowable panel thickness refer panel dimensions page 1 sec 1.2)

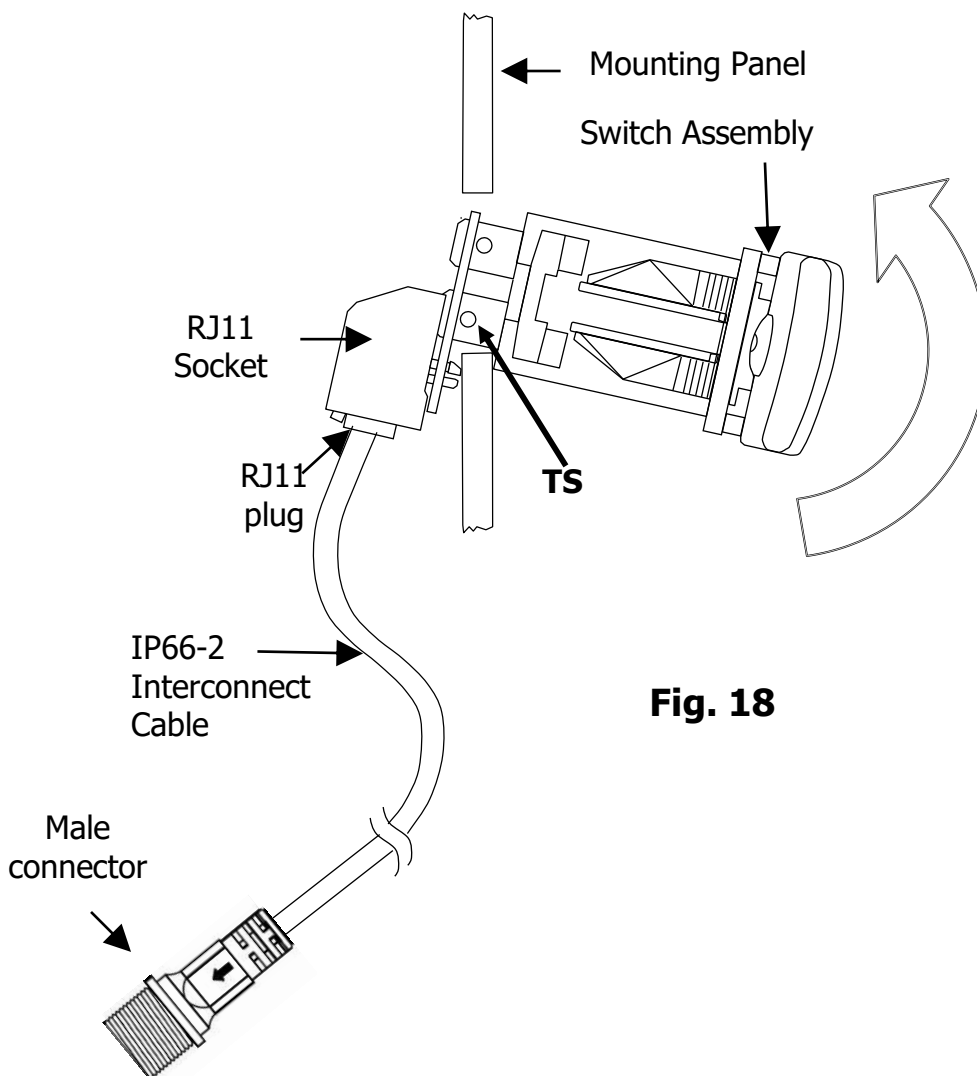

Questions?  
Call 1 877 787 8833

# S3VT Operating Switch and Cable Installation

## 10.4 Step 3 A and B

Unless rear is accessible, switch removal may prove difficult, requiring a special tool - be sure for complete readiness before proceeding with step 3

- Continue pushing the assembly into the Panel slot in the direction of arrows. **(Fig. 22 A)**
- Slide in firmly – towards the end resistance is felt as splines get compressed
- Push in firmly till seated flush.
- Splines will expand out and secure it in place. **(Fig. 22 B)**

**This completes your S3VT Switch and IP66-2 wiring install.  
Refer to Doc DM101 S3VT Install Instructions for final system test.**

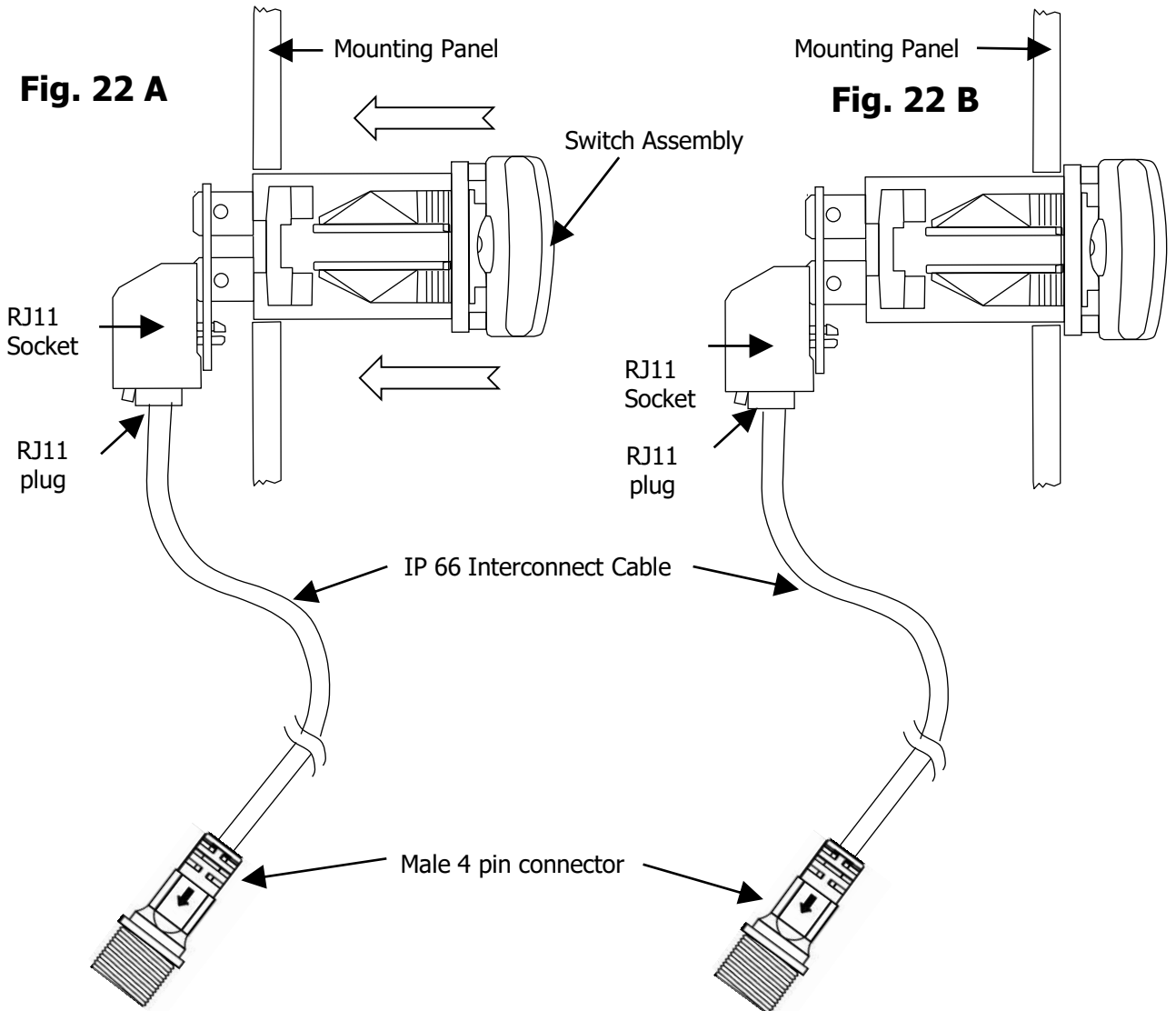

Questions?  
Call 1 877 787 8833

## S3VT Operating Switch and Cable Installation

Download or view S3VT companion documents in PDF format from 'Product Manuals' at our website.

S3VT is an upgraded product using newer style molded IP66 connectors and improved, more flexible cabling..

- DM101 S3VT Valve Installation
- DM103 S3VT Valve Configuration Guide
- DM104 S3VT 12V DC Wiring Diagram
- DM106 S3VT System Master Switch Installation
- DM107 S3VT Pro Series Valve Product and Mounting Space Dimensions

Help improve our documents

Please give your feedback

Toll Free 1 877 787 8833

email: [admin@drainmaster.com](mailto:admin@drainmaster.com)



Questions?  
Call 1 877 787 8833