

Drain Master *Marine*

Drain Master Electric Ballast Valve



Product Data

Drain Master is an electrically operated, one touch ballast valve designed to replace standard 3" gate valves on both motorized and towable recreational vehicle applications.

- Made of durable, injection molded ABS plastic.
- Ideal for black and gray water tank installations.
- Very fast gate opens or closes in less than one second, initiated by a switch located on the dash.
- Weighs less than two pounds, with ultra sleek profile.
- **Features 303 Stainless Steel, double sided manual override and gearing made in Switzerland**
- Operates on standard 12 volt battery systems, and draws less than 5 amps during operation.

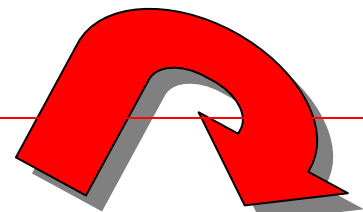

Drain Master Marine
The Perfect Solution

www.drainmaster.com 877-787-8833

Technical Specifications

- Height 10"
- Width 6"
- Depth 1 3/4" - 3/4"
- Valve Size 3"
- Weight 1 lb 14 oz
- Voltage 12 Volts DC
- Consume 2.5 amps per cycle
- Wire 20 AWG

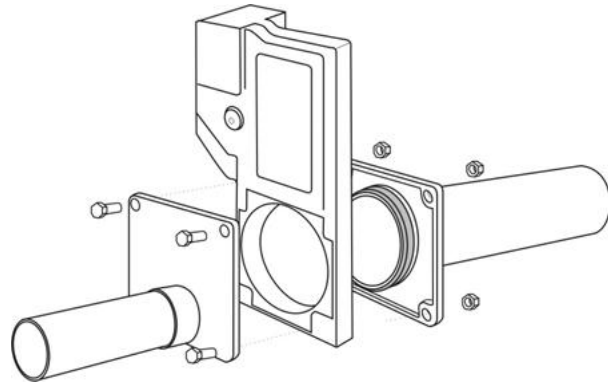

Torque Spec for Flange Bolts 20" (inch pounds)

Testing Data

Continuous Cycle Test	Cycle Weeks	=	Per Year	÷	Cycles	=	Years
	3 x 52		156		6000		38.46

