









Doc WM89

Drop Height and Hardware Configuration

- ✓ **WM 5911**
- ✓ **WM 5912**
- ✓ **All Kits with Enclosure and
Mounting Bracket**



Hardware Contents and Item Description

Item	Description	Qty	Remarks	Image
1	3/8" 16 TPI Cap Nuts	4	Used for protection from sharp edges and to mount the Tap bolt	
2	3/8" SAE Flat Washer	24	Not all may be used up – depends on configuration	
3	3/8" Lock Washer External Tooth	8	Kit may contain serrated head nuts and or / bolts in lieu of lock washers	
4	3/8" 16 TPI Nut	12	Kit may contain serrated head nuts in lieu of lock washers..	
5	3/8" ID Black Split Sheathing	12" L	Cut to size as needed to cover exposed part of bolt shanks	
6	1/4" ID Black Split Sheathing	14" L	Cut to size to cover edge of 4" dia. enclosure hole	
7	3/8" 16 TPI Tap Bolt 4.5"L *	4	Kit may optionally contain serrated head bolts in lieu of lock washers	
8	1/4" Dia x 3/4" L self drilling screws	6	Used to mount the Bracket to I-Beam. Pre drill 3/16 Pilot hole before install.	

Note: Part Pictures are not to scale - meant for identification purposes only

*4.5" Bolt Length supplied provides Drop Height range from 0.95" to 4.55".

Larger Drop heights need longer Tap bolts – purchase separately or order from Drain Master Inc.



HW Configuration 1

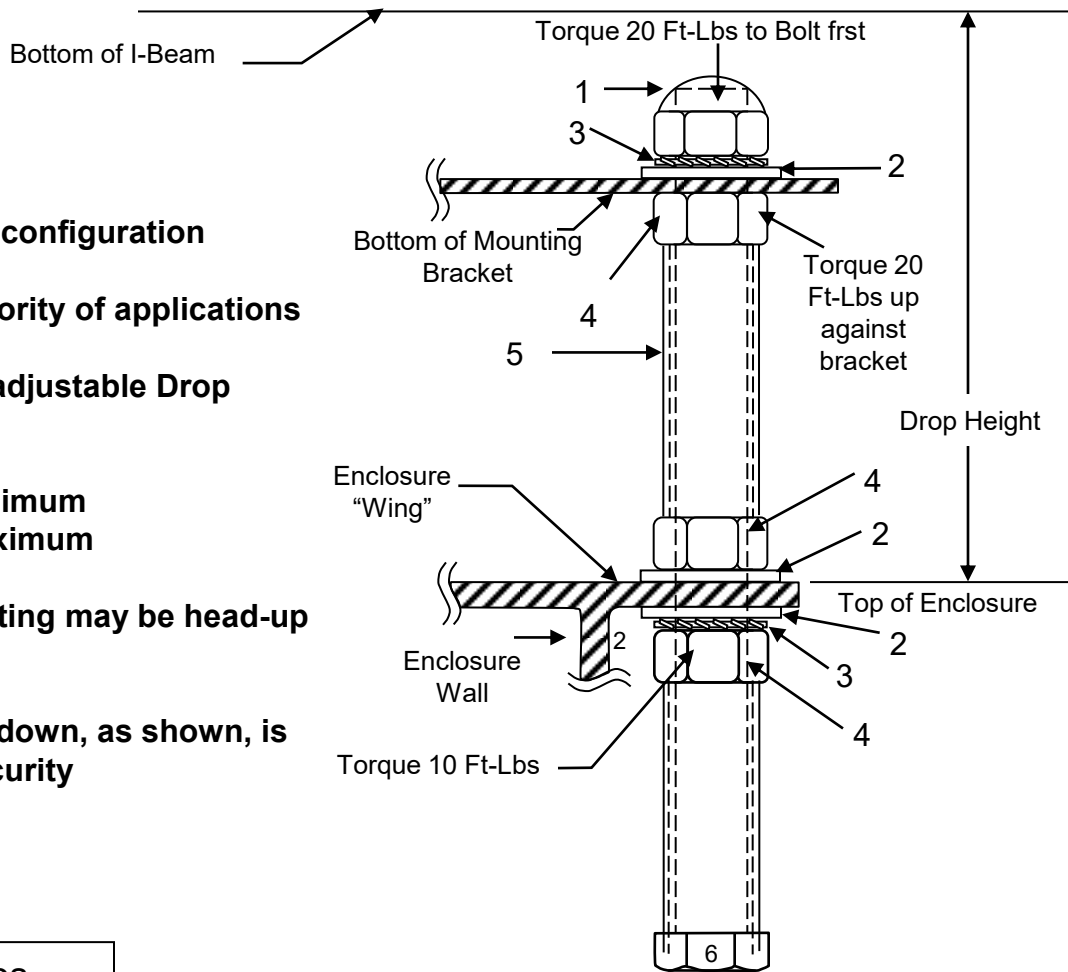

- ❑ **Most common configuration**
- ❑ **Works for majority of applications**
- ❑ **Continuously adjustable Drop Height range**
 - ✓ **1.66” Minimum**
 - ✓ **4.16” Maximum**
- ❑ **Tap Bolt mounting may be head-up or head –down**
- ❑ **Tap Bolt head-down, as shown, is favored for security**

Assembly Steps

1. Mock assemble HW items as shown in the enclosure ‘Wing’ Holes and mount to Mounting bracket; hand tight initially
2. Using middle nuts adjust Drop Height so hose cuff centers in side hole - 1/8”- 3/16” clearance recommended.
3. Measure exposed bolt shanks and cut sheathing to fit.
4. Final assemble with sheathing in place on the exposed bolt shanks; drop height will now be self set.
5. Use a permanent strength thread locker such as Loctite Red 127 or equivalent. Torque the Cap nuts (1) on the bolts to 20 Ft Lbs. Torque the lower nut (4) up against the Metal Bracket to 20 Ft Lbs.
6. Torque middle nuts to 10 Ft Lbs against the enclosure. Caution: Over torque may crack or stress material
7. Recheck and re-torque as needed over few RV trips till fully stable.



HW Configuration 2

- ❑ **4.55" Maximum drop Height achievable with 4.5" supplied bolts**
- ❑ **Drop height reduction fine tuning possible**
- ❑ **Head-down Tap Bolt mounting is essential**
- ❑ **Stack 1, 2, 3 or 4 flat washers as spacers under the enclosure wings to reduce Drop height in 1/16" steps from 4.55" to 4.29"**
- ❑ **Stacking an extra nut to the washer combination above gives additional fine adjustment range overlapping configuration 1.**

Be creative to devise your own combination

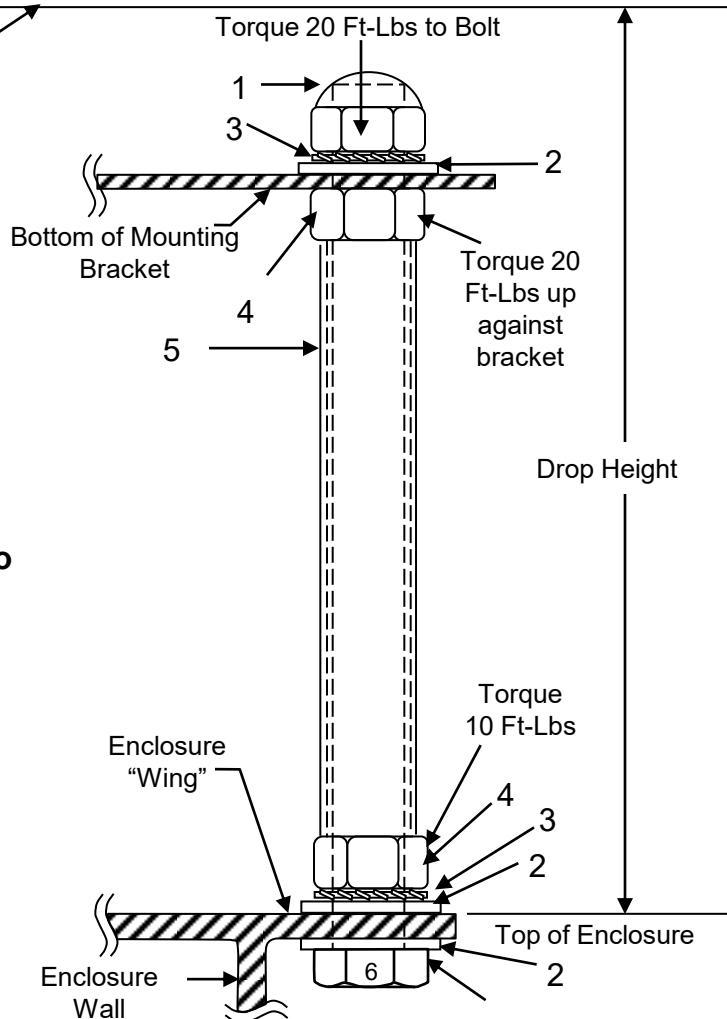

Assembly Steps

1. Mock assemble HW items as shown in the enclosure 'Wing' Holes and mount to Mounting bracket; hand tight initially
2. Fine Tune (reduce) Drop Height using a combination of flat washers or a combination of 1 nut and flat washers as spacers to center hose cuff in side hole - 1/8" - 3/16" clearance recommended.
3. Measure exposed bolt shanks and cut sheathing to fit.
4. Final assemble with sheathing in place or the exposed bolt shanks, Drop height will be self set.
5. Use a permanent strength thread locker such as Loctite Red 127 or equivalent. Torque the Cap nut (1) on the bolts to 20 Ft Lbs. Torque the lower nut (4) up against the Metal Bracket to 20 Ft Lbs.
6. Torque lowest nut to 10 Ft Lbs against the enclosure. Over torque may damage or stress enclosure
7. Recheck and re-torque as needed over few RV trips till fully stable.



HW Configuration 3

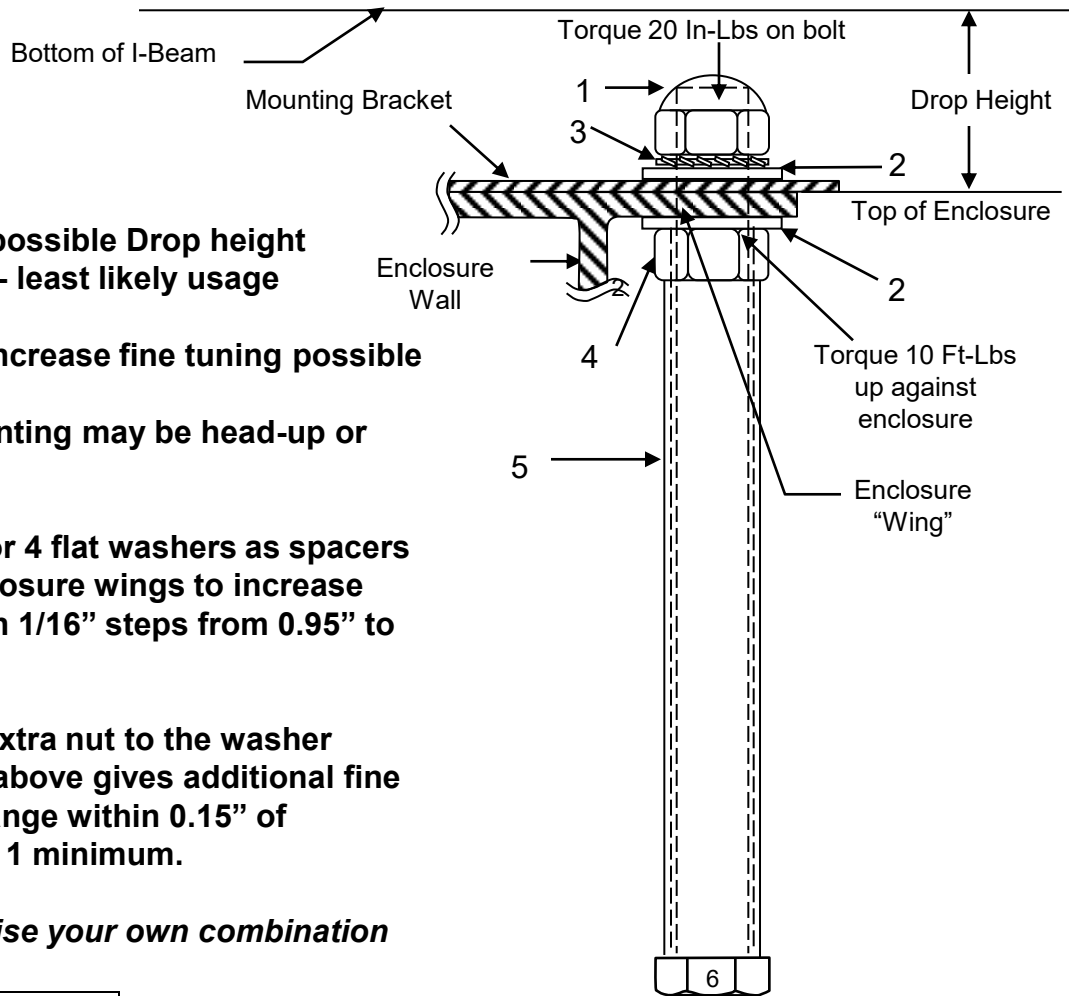

- 0.95" lowest possible Drop height configuration- least likely usage**
- Drop height increase fine tuning possible**
- Tap Bolt mounting may be head-up or head-down**
- Stack 1, 2, 3 or 4 flat washers as spacers over the enclosure wings to increase Drop height in 1/16" steps from 0.95" to 1.21"**
- Stacking an extra nut to the washer combination above gives additional fine adjustment range within 0.15" of configuration 1 minimum.**

Be creative to devise your own combination

Assembly Steps

1. Mock assemble HW items as shown in the enclosure 'Wing' Holes and mount to Mounting bracket; hand tight initially
2. Fine Tune (increase) Drop Height using a combination of flat washers or a nut and washers stack combination as spacers to center hose cuff in side hole - 1/8"- 3/16" clearance recommended.
3. Measure exposed bolt shanks and cut sheathing to fit.
4. Final assemble with sheathing in place or the exposed bolt shanks, Drop height will be self set.
5. In this configuration using a permanent strength thread locker such as Loctite Red 127 or equivalent **is a must**.. Torque the Cap nut (1) on the bolt to 20 Ft Lbs. Torque the lower nut (4) up against the Enclosure wing to 10 Ft Lbs. Over torque may damage or stress enclosure.
6. Recheck and re-torque as needed over few RV trips till fully stable.



Actual Installation Examples



***Congratulations on your
successfully installing the
Waste Master storage
system! Now you can enjoy
the ultimate in convenience.***

***Questions? Comments?
Need Help?***

Call Toll Free: 877-787-8833

